

IR LP300 & LP500

High efficiency IR-beam system



Product number: LP300-xx65/LP500-xx65

Notes:

The LP300 and LP500 IR-system are available with a 15° x 30° lens (the IR distribution of which is shown in the diagram at the bottom), a 30° x 60° lens or a 60° x 90° lens.

All of these provide an asymmetrical light dispersion, resulting in a rectangular area of equal illumination.

These IR systems are designed to work especially well with surveillance cameras and similar systems. The advanced optics reduces almost all stray light and the efficient filter gives a 95% IR transmission from 810nm.

Asymmetrical 15° x 30° lens dispersion diagram

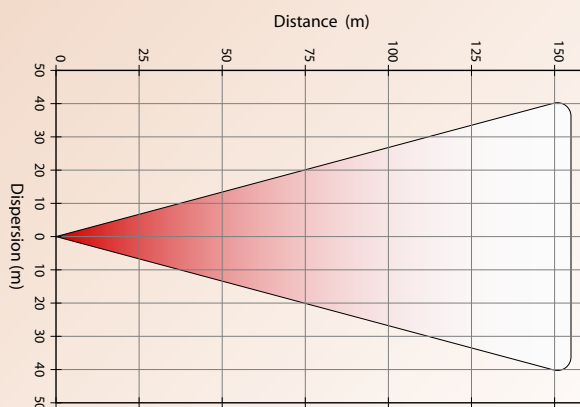



IR LP300 & LP500

High efficiency IR-beam system

IR system LP300 / LP500

Product number: LP300-xx65/LP500-xx65
Light source: 6874P (300W) / 6877P (500W)
Colour Temp.: 2000 °K
Average Lifetime: 2000 h
Ex. applications: Illumination for IR-cameras
Transmittance characteristics for IR-filter:

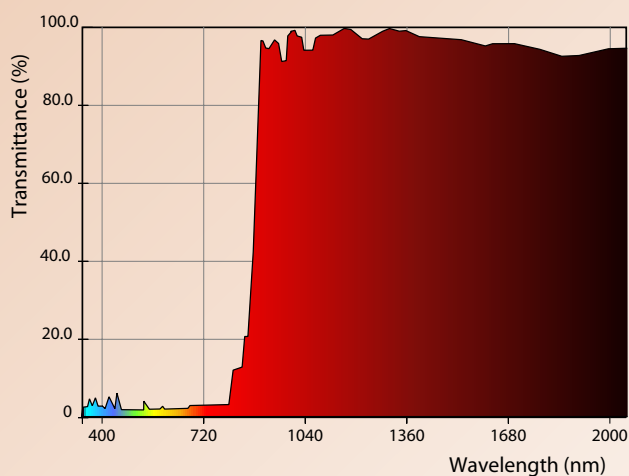

Technical schematic

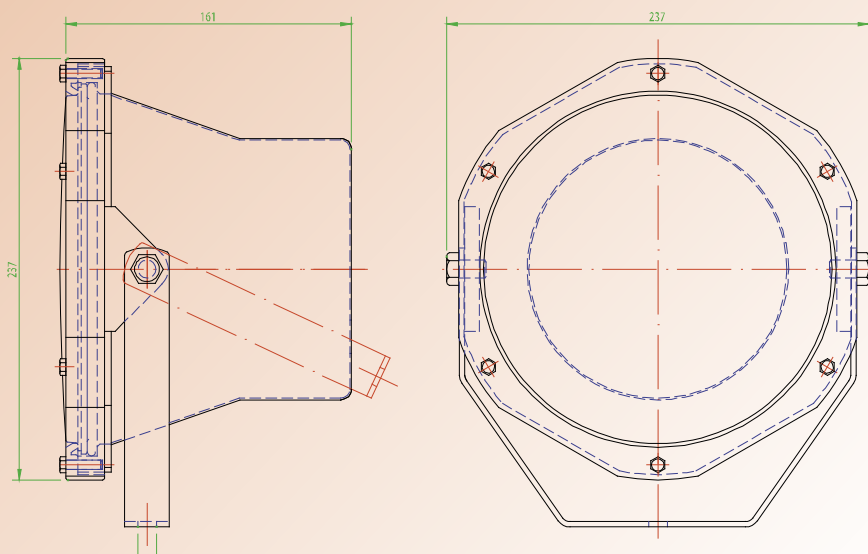

Data

Technical data

Temp. range: -40/+70 °C
Reflector: Ø 200 mm
Protection code: IP 65

Electrical data

Output 240V AC: 300W/500W

Measurements

Length: 161 mm
Height: 237 mm
Width: 237 mm
Weight: 2.4 kg



Prismalence AB
Sörmesunda 183, 895 91 Bredbyn
Sweden, +46 (0) 660-843 35

Web site: www.prismalence.se
Sales: Daniel Bergkvist, daniel@prismalence.se
Technical: Olov Bergkvist, olov@prismalence.se

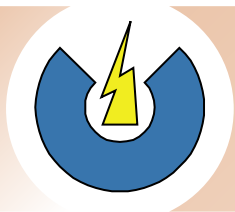

IR LP300 & LP500

High efficiency IR-beam system

Handling and Care instructions:

The LP 300 and LP500 develop a considerable amount of heat and should always be handled carefully after they have been operating for some time. There is an IR filter fixed to the reflector. This filter is important and well protected behind the lens, it is however, vulnerable when you are changing the lightbulb -see the instructions below. Also due to the heat produced, we recommend that the continuous operation of the LP300 do not exceed 4 hours and the more powerful LP500 should not be left on for more than 3 hours.

How to change the lightbulb:

First disconnect any current, then unscrew the 6 screws on the front. Remove the front ring and the lens and remove the unit consisting of the reflector, filter and socket from the hood. Place this unit, filter-down on a piece of clean cloth or similar. Proceed by unscrewing the two screws at the top (one of them is connected to the earth-wire), not the two going in sideways into the seating and the reflector. Now lift the socket carefully and remove the lightbulb by pulling it straight out of the socket, using its ceramic base -do not hold onto the glass when handling the bulb. Insert the new bulb and re-attach the socket. Now replace the hood and tilt up the lamp, but before replacing the screws, make sure that the lens is properly aligned or else the illuminated area will be distorted. During the whole procedure, the filter must not be touched with bare hands as the grease from your fingers will degrade the performance significantly, as will any other contamination.

